

Pressure valve Sequence function

$Q_{\max} = 140 \text{ l/min}$, $p_{\max} = 350 \text{ bar}$
pilot operated, spool type, mechanically adjustable
Type series: DVPA-3D-10-...

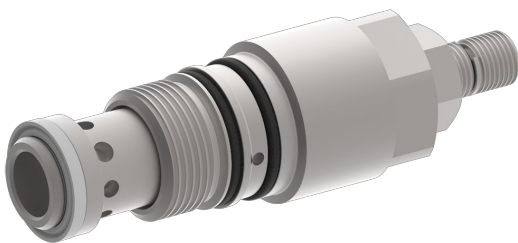

- Screw-in cartridge valve
- For cavity DD
- All external parts with zinc-nickel plating according to DIN EN ISO 19598
- Installation in threaded port body type DDY-12
- The external oil drain allows pressure setting without interference by the secondary pressure
- Very stable operation
- Responsive pressure adjustment
- Seated pilot stage

Description

These two-stage pressure relief valves, series DVP_-3D-..., are size 10, screw-in cartridge valves with a seated pilot stage and an M24×1.5 mounting thread. They are designed on the proven sliding-spool principle. The spring chamber is internally drained to port Z. Back pressure applied to port B does not influence the valve relief setting. To obtain a reliable pressure setting over the entire pressure range, the overall pressure range is divided into different pressure levels. Each pressure range corresponds to a particular spring that allows a certain maximum oper-

ating pressure to be set. The pressure is set by means of an adjusting spindle. All external parts of the screw-in valves are zinc-nickel plated and are thus suitable for use in the harshest operating environments. These valves are mainly used in certain mobile and industrial applications to limit the system pressure. Thanks to the external oil drain, the actuator port can be pressurized without affecting the setting. For self-assembly, please refer to the section related data sheets.

Symbol

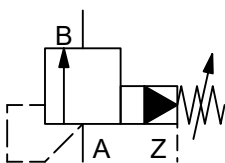

Technical data

General characteristics	Description, value, unit
Function group	Pressure valve
Function	Sequence function
Design	Screw-in cartridge valve
Controls	mechanically adjustable
Characteristic	pilot operated, spool type
Construction size	NG 10
Thread size	M24×1,5
Mounting attitude	unrestricted
Weight	0.23 kg
Cavity acc. factory standard	For cavity DD
Tightening torque steel	65 Nm
Tightening torque aluminium	50 Nm
Tightening torque tolerance	± 10 %
Minimum ambient temperature	- 30 °C
Maximum ambient temperature	+ 80 °C
Surface protection	All external parts with zinc-nickel plating according to DIN EN ISO 19598
Sealing material	see ordering code
Seal kit order number	NBR: DS-216-N / FKM: DS-216-V

Hydraulic characteristics	Description, value, unit
Maximum operating pressure	350 bar
Maximum flow rate	140 l/min
Flow direction	see symbol
Hydraulic fluid	HL and HLP mineral oil according to DIN 51 524; other fluids on request!
Minimum fluid temperature	- 30 °C
Maximum fluid temperature	+ 80 °C
Viscosity range	10 ... 650 mm ² /s (cSt)
Recommended viscosity range	15 ... 250 mm ² /s (cSt)
Minimum fluid cleanliness (cleanliness class according to ISO 4406:1999)	class 20/18/15
Pilot-oil consumption	0,15...6 l/min
Minimum set pressure	10 bar
Maximum set pressure	350 bar
Pressure adjustment range	pressure range L: 1 turn = ca. 13 bar pressure range M: 1 turn = ca. 38 bar pressure range N: 1 turn = ca. 65 bar

Performance graphs

measured with oil viscosity 33.0 mm²/s (cSt)

$\Delta p = f(Q)$ Pressure drop-flow rate characteristic

Δp [bar (psi)]

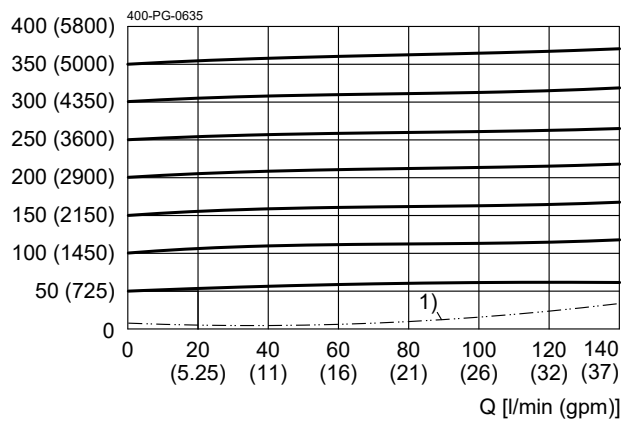

Druckeinstellung Typ N / pressure range type N
 $p_N = 350$ bar (5000 psi)
 1) Einsatzgrenze / Application limit

$\Delta p = f(Q)$ Pressure drop-flow rate characteristic

Δp [bar (psi)]

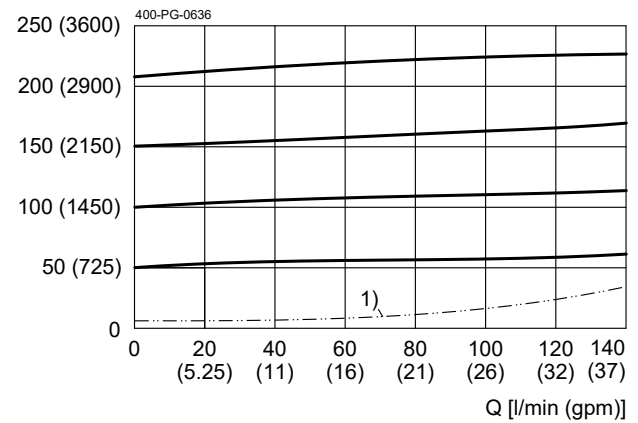

Druckeinstellung Typ M / pressure range type M
 $p_N = 210$ bar (3000 psi)
 1) Einsatzgrenze / Application limit

$\Delta p = f(Q)$ Pressure drop-flow rate characteristic

Δp [bar (psi)]

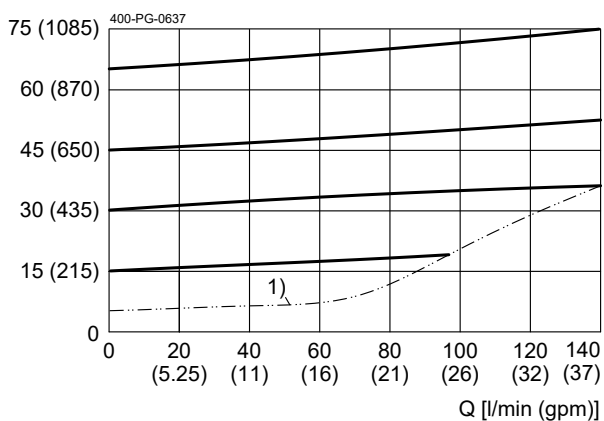

Druckeinstellung Typ L / pressure range type L
 $p_N = 65$ bar (940 psi)
 1) Einsatzgrenze / Application limit

$QL = f(p; \Delta p)$ Leakage flow rate

QL [cm³/min]

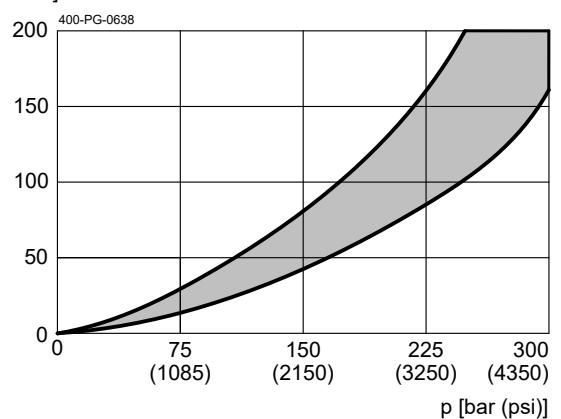

Vorgesteuert geschlossen/
 pilot-controlled closed

Dimensions and sectional view

Beispiel für die Masseinheit:
Example for the dimensional units:

0.79 = 0.79 mm millimeter
(.031) = 0.031" inch

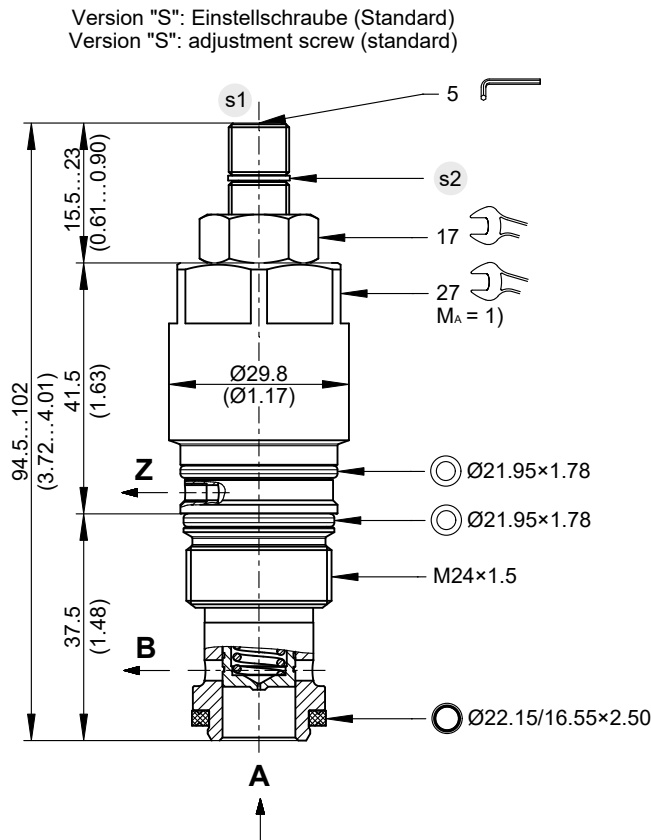

Version "H": Einstellschraube mit Handrad
Version "H": adjustment screw with handknob

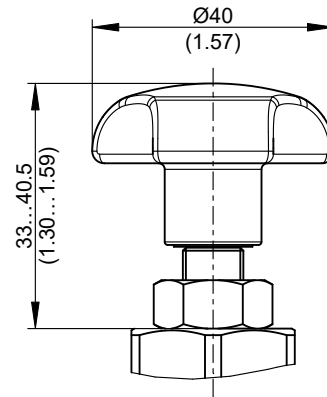

Einstellschraube mit Sicherungskappe
adjustment screw with tamper-proof cap

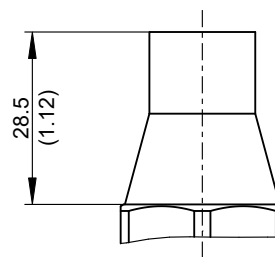

Installation information



ATTENTION!

Only qualified personnel with mechanical skills may carry out any maintenance work. Generally, the only work that should ever be undertaken is to check, and possibly replace, the seals. When changing seals, oil or grease the new seals thoroughly before fitting them.



NOTE!

Set the required pressure with the adjusting screw (s1). After you have set the valve, lock the adjusting screw (s1) with the lock nut.



NOTE!

1) When fitting the screw-in cartridge valve, use the specified tightening torque. The value can be found in the chapter "Technical data".



NOTE!

The seals are not available individually. The seal kit order number can be found in the chapter "Technical data".

Ordering code

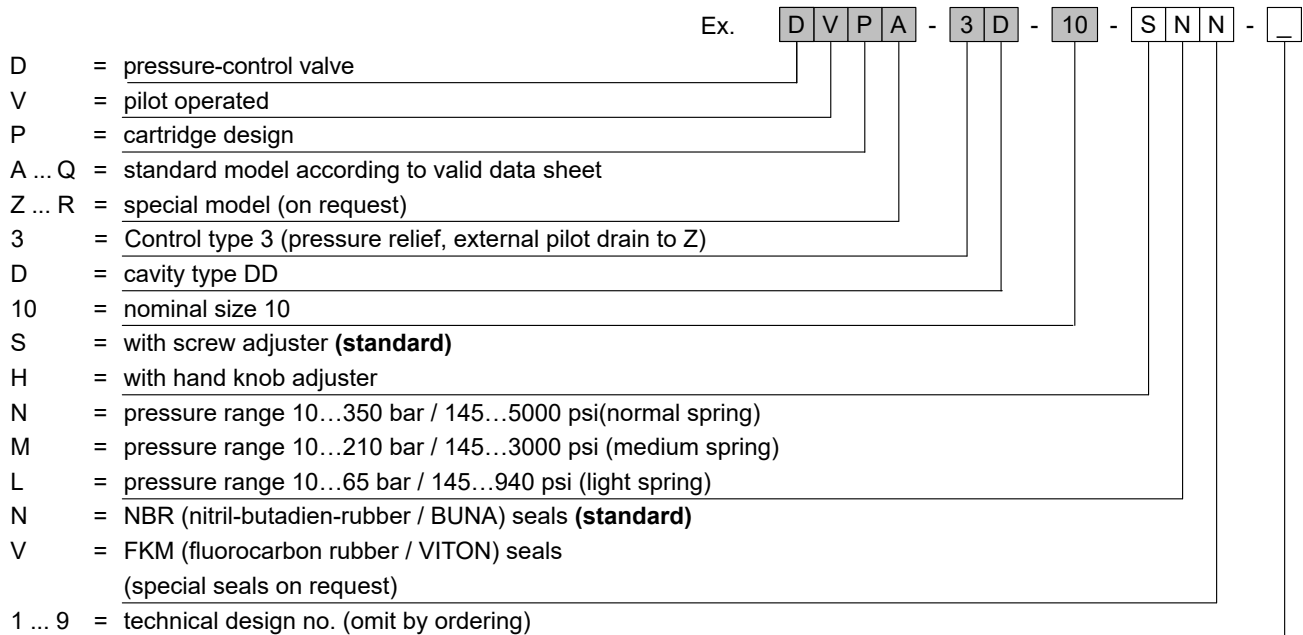

IMPORTANT!

When required, the tamper-proof cap (the adjustment seal) must be ordered separately in plain language.

Related data sheets

Reference	Description
400-P-040011	Form tools
400-P-060121	Cavity DD
400-P-740112	Threaded port body DDY-12